

CARATTERISTICHE COSTRUTTIVE / CONSTRUCTION FEATURES  
CARACTERÍSTICAS CONSTRUCTIVAS / CARACTÉRISTIQUES D'EXÉCUTION

<b>Corpo pompa</b> <b>Pump body</b>	acciaio cromo-nichel AISI 304 stainless steel AISI 304
<b>Cuerpo bomba</b> <b>Corps de pompe</b>	acero cromo-níquel AISI 304 acier chrome-nickel AISI 304
<b>Supporto motore</b> <b>Motor bracket</b>	alluminio aluminium
<b>Soporte motor</b> <b>Support moteur</b>	aluminio aluminium
<b>Giranti, diffusori</b> <b>Impellers, diffusers</b> <b>Rodetes, difusores</b> <b>Turbines, diffuseurs</b>	Noryl®
<b>Tenuta meccanica</b> <b>Mechanical seal</b> <b>Sello mecánico</b> <b>Garniture mécanique</b>	ceramica-grafite ceramic-graphite cerámica-grafito céramique-graphite
<b>Albero motore</b> <b>Motor shaft</b> <b>Eje motor</b> <b>Arbre moteur</b>	acciaio cromo-nichel AISI 303 stainless steel AISI 303 acero cromo-níquel AISI 303 acier chrome-nickel AISI 303
<b>Temperatura del liquido</b> <b>Liquid temperature</b> <b>Temperatura del líquido</b> <b>Température du liquide</b>	-5 ÷ +35 °C
<b>Pressione di esercizio</b> <b>Operating pressure</b> <b>Presión de trabajo</b> <b>Pression de fonctionnement</b>	max 7 bar
<b>MOTORE / MOTOR / MOTOR / MOTEUR</b>	
<b>Motore 2 poli a induzione</b>	3~ 230/400V-50Hz
<b>2 pole induction motor</b> <b>Motor de 2 polos a inducción</b> <b>Moteur à induction à 2 pôles</b>	1~ 230V-50Hz (con termoprotettore fino a 1,85kW with thermal protection up to 1,85 kW con protección térmica hasta 1,85 kW avec protection thermique jusqu'à 1,85 kW)
<b>Classe di isolamento</b> <b>Insulation class</b> <b>Clase de aislamiento</b> <b>Classe d'isolation</b>	F
<b>Grado di protezione</b> <b>Protection degree</b> <b>Grado de protección</b> <b>Protection</b>	IP44



Pompe centrifughe multistadio orizzontali **autoadescenti**. Adatte alla movimentazione di liquidi non carichi; sistemi di pressurizzazione; irrigazione; acque potabili o con glicole in soluzione; trattamento acque; industria alimentare; riscaldamento e condizionamento; sistemi di lavaggio.

Stainless steel multistage horizontal **self-priming** pumps. Pumping of clean non-loaded fluids; pressurizing system; irrigation; drinking and glycol water; water treatment; heating and air conditioning; washing system.

Bombas centrifugas multietapas horizontales **autocebantes**. Bombeo de líquidos químicamente y mecánicamente no agresivos; sistemas de presurización; riegos; agua potable o con glycol; tratamientos del agua; industria alimenticia; calefacción y refrigeración; sistemas de lavado.

Pompes centrifuges multicellulaires horizontales **auto-amorçantes**. Pompage d'eaux propres non chargées; groupes de surpression; irrigation; eau potable ou solution de glycol; traitement des eaux; industrie alimentaire; chauffage et climatisation; stations de lavage auto.

## U 3 A - 100/5 T

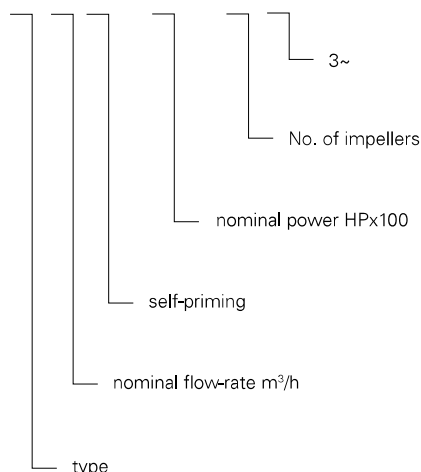

ULTRA A

3 A

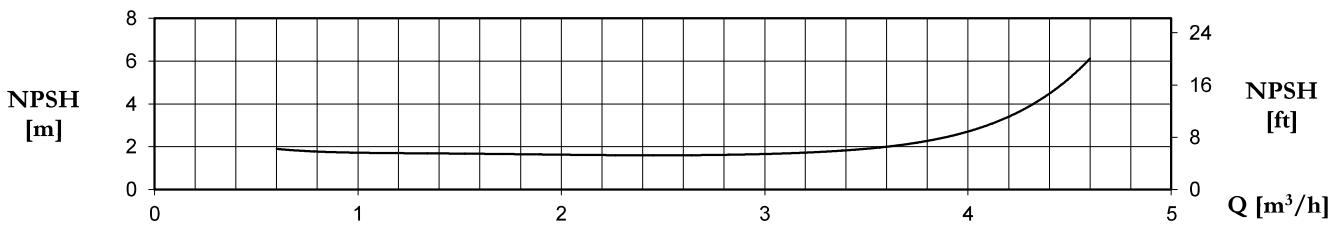
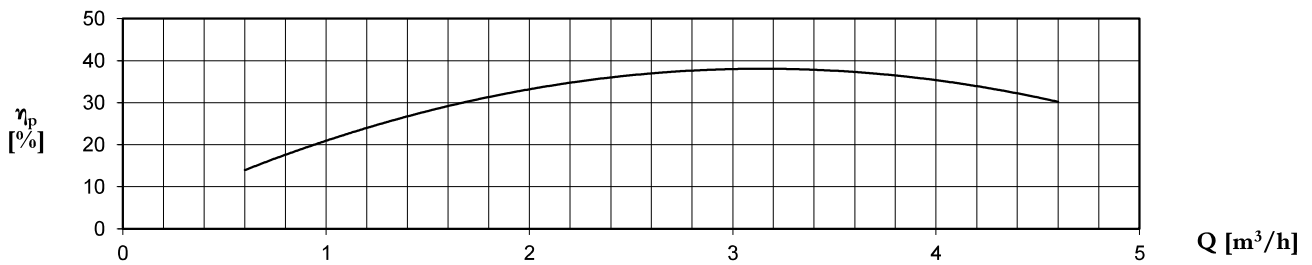
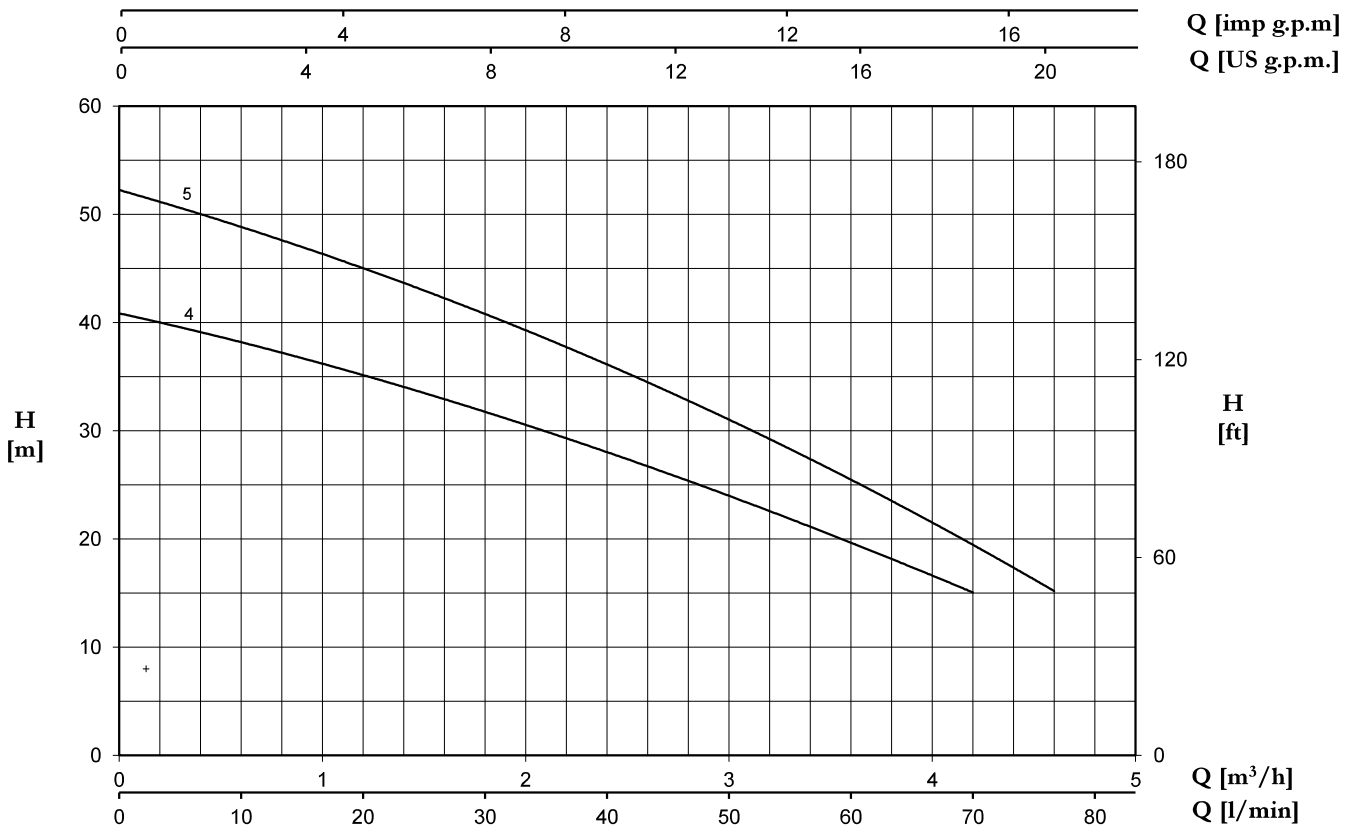

TYPE		P2		P1 (kW)		AMPERE		Q (m³/h - l/min)							
1~	3~	(HP)	(kW)	1~	3~	1~	3~	0	0,6	1,2	1,8	2,4	3,6	4,2	4,6
								0	10	20	30	40	60	70	76,7
						1x230 V 50 Hz	3x400 V 50 Hz	H (m)							
U 3A-90/4	U 3A-90/4T	0,9	0,66	0,9	0,88	4	1,8	40,8	38,3	35,1	31,8	27,9	19,8	15,0	-
U 3A-100/5	U 3A-100/5T	1	0,75	1,06	1,01	4,8	1,9	52,2	48,9	45,1	40,8	36,0	25,4	19,8	15,0

# 5 A

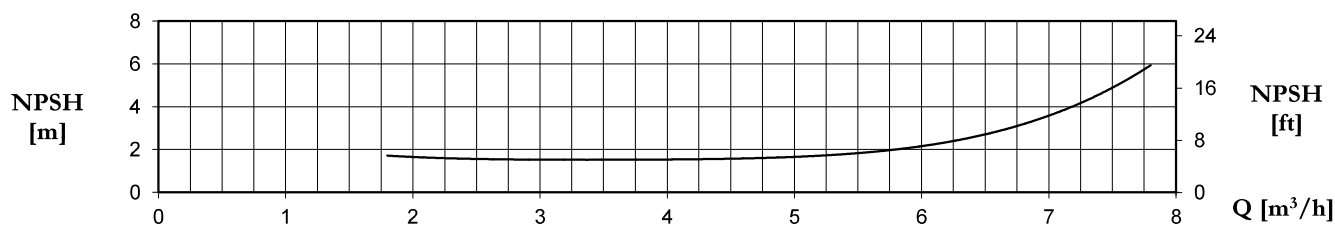
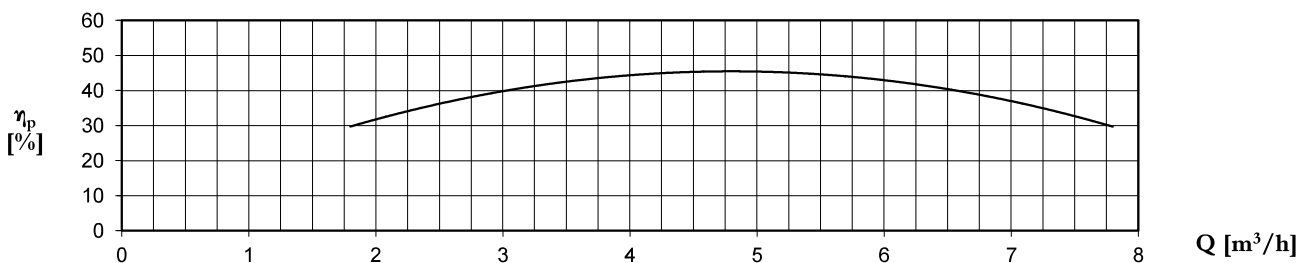
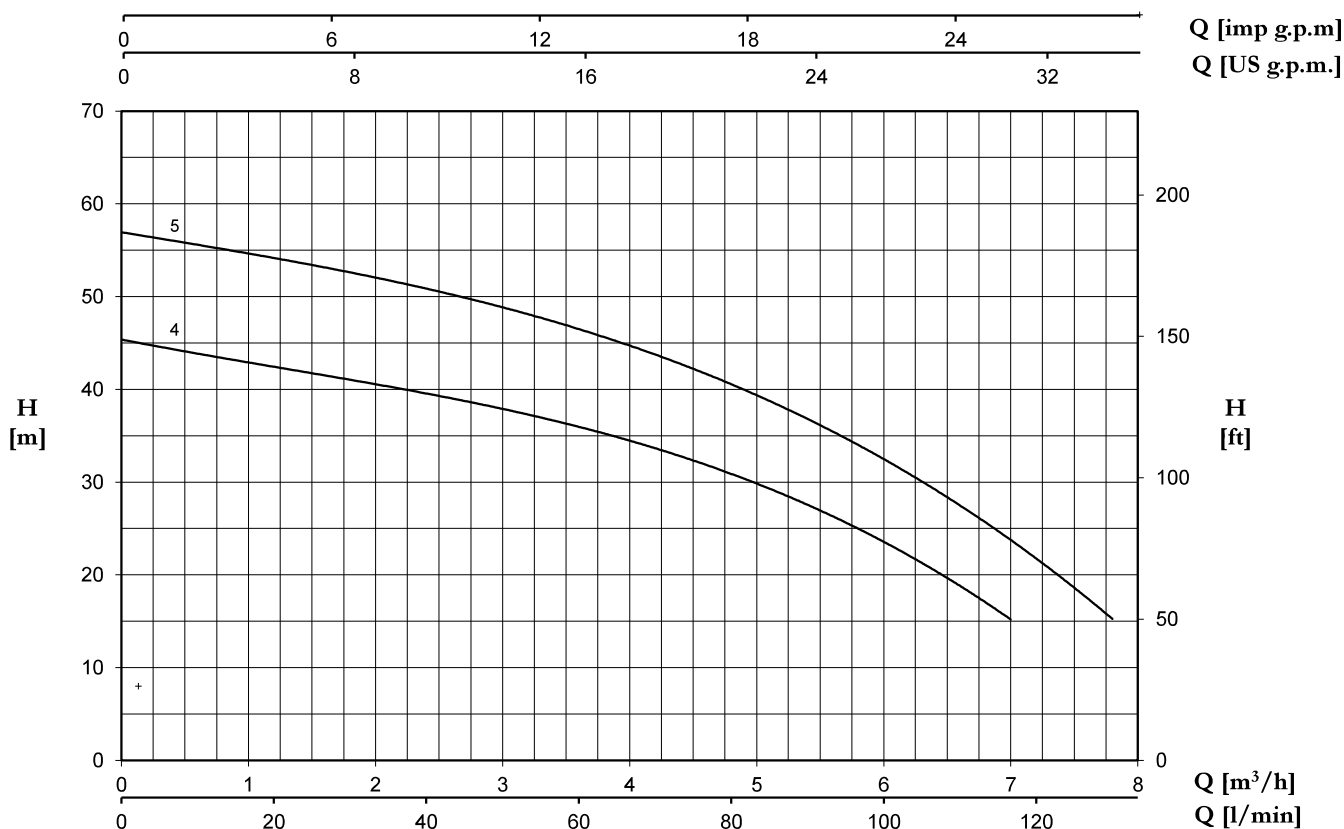

TYPE		P2		P1 (kW)		AMPERE		Q (m³/h - l/min)							
1~	3~					1~	3~	0	1,8	2,4	3,6	4,8	6	7	7,8
		(HP)	(kW)	1~	3~	1x230 V 50 Hz	3x400 V 50 Hz	H (m)							
U 5A-120/4	U 5A-120/4T	1,2	0,9	1,13	1,13	5,2	2,5	45,3	41,3	39,6	35,6	30,8	24,0	15,0	-
U 5A-150/5	U 5A-150/5T	1,5	1,1	1,47	1,39	6,8	2,8	56,8	53,0	51,0	46,1	40,1	33,0	24,0	15,0

# ULTRA A

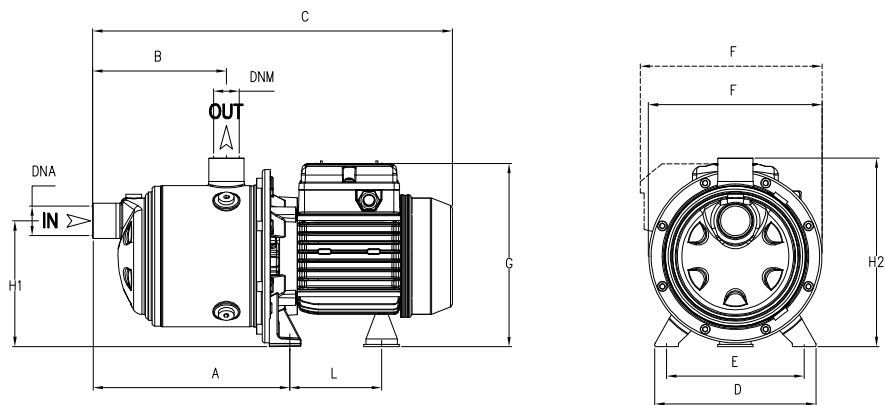

TYPE	DIMENSIONS (mm)										Kg	DNA	DNM
	A	B	C	D	E	F	G	L	H1	H2			
<b>U 3A-90/4</b>	190,8	175,0	405,0	164,0	140,0	178,0	190,0	93,7	128,0	192,0	8,5	1" G	1" G
<b>U 3A-100/5</b>	214,8	199,0	452,0	164,0	140,0	178,0	203,0	104,7	128,0	192,0	10,8		
<b>U 5A-120/4</b>	190,8	175,0	428,0	164,0	140,0	178,0	203,0	104,7	128,0	192,0	11,3		
<b>U 5A-150/5</b>	214,8	199,0	484,0	164,0	140,0	201,0	211,0	128,2	134,0	198,0	13,7		

TYPE	TRUCK		CONTAINER	
	PALLET (cm)	N° pumps	PALLET (cm)	N° pumps
<b>U 3A-90/4</b>	85x110x160	70	85x110x185	80
<b>U 3A-100/5</b>	80x120x150	42	80x120x175	49
<b>U 5A-120/4</b>	80x120x150	42	80x120x175	49
<b>U 5A-150/5</b>	80x120x150	42	80x120x175	49